

1. Scope

This document sheet is prepared to specify the technical parameters of the Lithium Ion prismatic cell model 15010018 supplied under AMS Batteries.

2. Product Classification

Category: Lithium Ion batteries

Chemistry: NMC

Classification: Class 9 Hazardous Goods.

Model: 15010018 20ah

3. Technical Parameters

Parameters	Specifications
Nominal Voltage	3.7 Volts
Charging Voltage	4.2 Volts
Discharge Cut off Voltage	2.75 Volts
Charging Current	Standard : 20A Rapid : 60A Maximum : 100A
Discharging Current	Standard : 20A Rapid : 200A Maximum : 300A (Not for continuous draw)
Capacity	Standard Discharge : 20000mAh Rapid Discharge : 19200mAh
Charging Method	Limited Current , Constant Voltage (CC-CV)
Cycle Life	Capacity > 16000mAh after 1000 Cycles Charge @ 0.25C Discharge @ 1C
Cell Weight	550 gms
Energy Density	140 Wh / Kg
Cell Dimensions	Cell Height : 150mm Cell Width : 100mm Cell Thickness : 18mm
Operating Temperature	Charge : 0-45°C Discharge : -20-60°C
Storage Temperature	1 Month : -20 to 60°C 3 Months : -20 to 40°C 1 Year : -20 to 20°C
Shelf Life	10 years
Initial Internal Impedance	≤ 10mΩ

* The battery should strictly be used as per above parameters only any mishandling may cause serious damages.

4. Physical Appearance

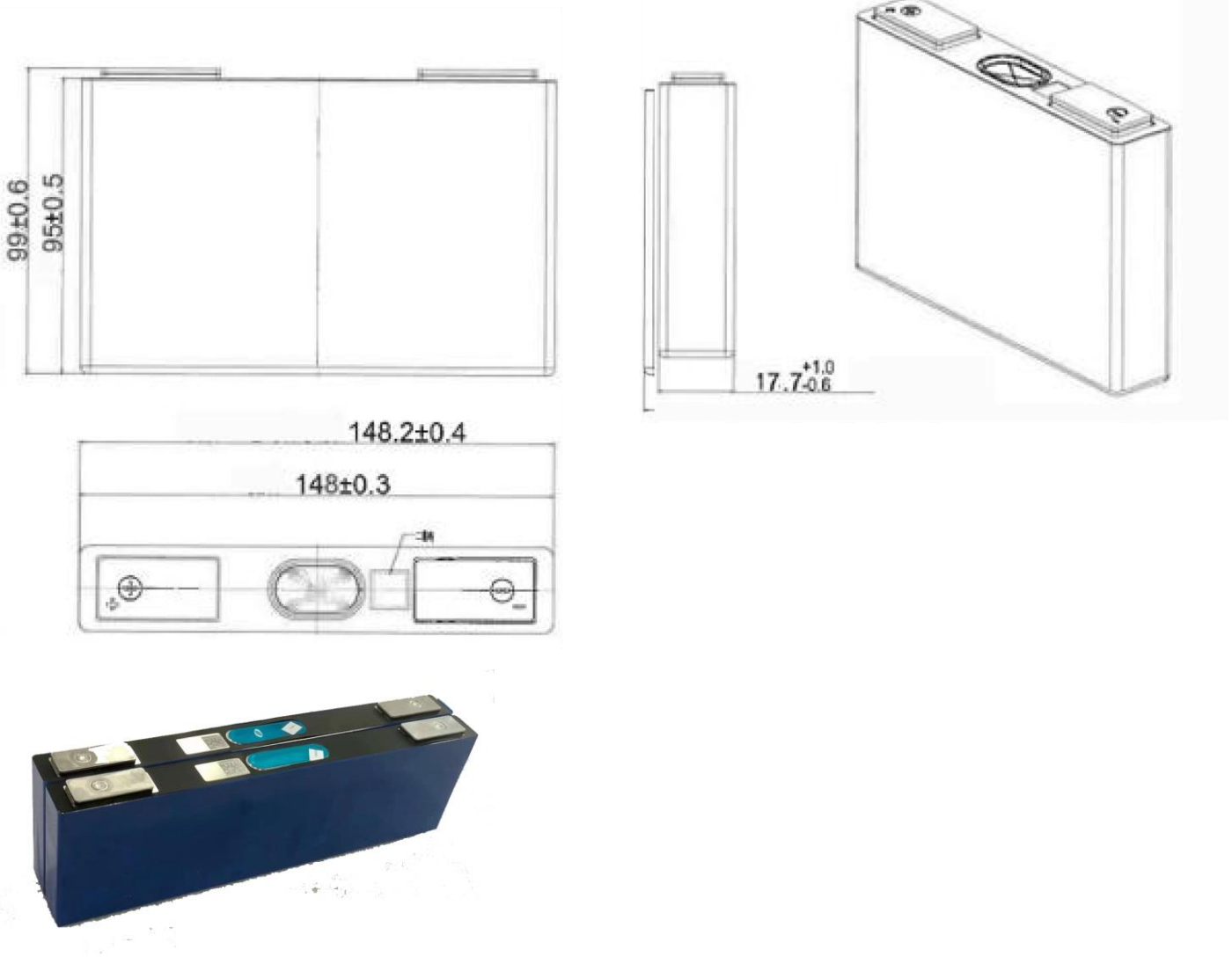

Height: 150mm (Approximately) Width: 100 mm (Approximately) Thickness: 18 mm (Approximately)

Note: The battery should be free from Dents, Cracks, Rust, Discolouration, and leakage which may impact the performance of the cell.

The cell should be shipped in 3.45V ~ 3.6V Charging voltage range.

5. Discharge and Charge Characteristics

Capacity obtained while discharging the cells at different temperature level intervals

Discharge rate	-10 °C	0°C	20 °C	40 °C
Capacity achieved	65%	80%	95%	93%

Capacity obtained while discharging the cells at different discharge levels

Discharge rate	0.2 C	1C	5C	10C
Capacity achieved	100%	99%	94%	85%

6. Cell Packing



7. Environmental Tests

All tests herein are conducted at standard humidity and temperature as per UL1642 & GB 31241 Standard.

Tests	Parameters	Impact
Electrical Tests		
Short Circuit test	To full charge a cell and short circuit it by connecting it to a resistance of <100 mΩ and has to be closely monitored for any fire or explosion until it reaches its ambient temperature and is discharged until 0.2V	No fire , No explosion Passed
Overcharge test	To Charge the cell >1C for no less than 8 hours	No fire , No explosion Passed
Over discharge test	To reverse charge a discharged cell for >90 mins at 1C	No fire , No explosion Passed
Forced Temperature test	To heat up the cell in intervals of 5°C every minute until it reaches 110°C and then the cells to be kept in oven for 30 minutes	No fire , No explosion Passed
Mechanical Tests		
Shock test	The cells in full charged condition shall be loaded on test surface at 0° inclination, Cell to be clamped with bolts and amplitude to be set to 30g (half sine wave) with a shock width of > 5 seconds.	No leakage Passed
Vibration test	As to the UN transportation regulation(UN38.3), for each axis (X and Y axis with cylindrical cells) 7Hz→200Hz→7Hz for 15min, repetition 12 times totally 3hours, the acceleration 1g during 7 to 18Hz and 8g (amplitude 1.6mm) up to 200Hz. UN38.3 Standard to be followed	No leakage Passed
Drop test	The cells in full charged condition shall be dropped from a height no less than 1 meter on a flat ground and kept to rest and then a visual inspection to follow IEC 62133 requirement to be followed	No fire , No explosion Passed

8. Cautions for cell usage

- a. Before using the battery in the application please refer to the application compatibility with the cells.
- b. Cells Storage temperature conditions to be met while storage.
- c. Take utmost care of the polarity reverse polarity may cause severe damage to the application intended.
- d. Avoid overcharging and discharging below specified levels
- e. Battery must be stored at lower temperatures and dry areas for optimal life.
- f. Battery must not be kept in direct sunlight, heat or high static environment and should be away from children and pets
- g. Do not disassemble, pierce, throw/dispose, incinerate or dissolve in water or any liquid.

9. Cautions for battery pack assembling and usage

- a. Cells should only be assembled by Battery pack Manufacturers only
- b. When a metal plate is kept on the cell top utmost care should be taken while welding and assembling and excessive pressure should not be applied which may lead to cell leaking or puncture and thermal runways.
- c. Cells from different lots should be avoided unless stated by AMS. The IR and voltages of the cells should be thoroughly checked before pack making and cells of different capacity or different brands should not be assembled together
- d. Do not use old and new cells together
- e. Each cell should be visually checked for any defects or damage.
- f. The design of battery pack and its structure should be reviewed physically, mechanically and electrically not to cause cell imbalance or other dangerous effects.
- g. BMS must compulsorily be installed in all the packs and every Bms should have below protections
 - i. Over voltage protection
 - ii. Under voltage protection
 - iii. Over Charge current protection
 - iv. Over Discharge current protection
 - v. Short circuit protection
 - vi. Over Temperature protection
 - vii. 2nd over voltage protection
 - viii. FET failure protection
 - ix. Cell imbalance protection circuit
 - x. Cell Voltage balancing function

10. Limitations of Liability

Defects caused by normal wear and tear, inadequate maintenance, handling, storage faulty repair, modification to the battery or pack by a third party other than AMS or AMS's agent approved by AMS, failure to observe the product specification provided herein or improper use or installation, including but not limited to, the following: -. Damage during transport or storage -. Incorrect installation of battery into pack or maintenance -. Use of battery or pack in inappropriate environment -. Improper, inadequate, or incorrect charge, discharge or production circuit other than stipulated herein -. Incorrect use or inappropriate use -. Insufficient ventilation -. Ignoring applicable safety warnings and instructions -. Altering or attempted repairs by unauthorized personnel -. In case of force majeure (ex. lightning, storm, flood, fire, earthquake, etc.) There are no warranties implied other than those stipulated by AMS. AMS shall not be liable for any consequential or indirect damages arising or in connection with the product specification, battery or pack.